

Loose Oil Rings

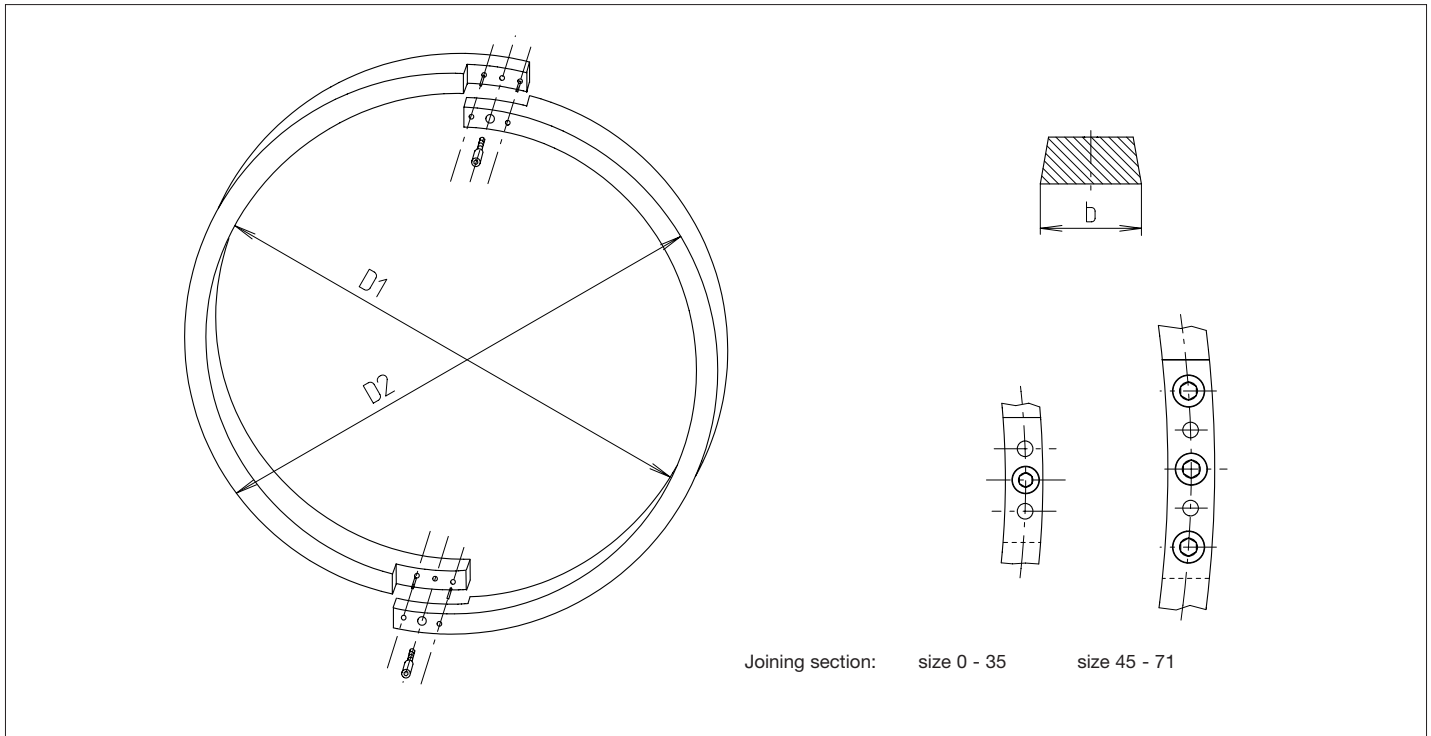

RENK loose oil rings are used with slide bearings series ZM and E. They ensure the delivery of the lubricant to the shaft journal.

The loose oil rings are very precise machine elements, supplied in a split version.

Depending upon the application, it is also possible to use loose oil rings with other bearing types.

Material

The loose oil rings are made from a copper-zinc alloy.

Dimensions

The table on the right side shows the coding, the marking and the sizes available, as well as the association to the corresponding shaft dimensions. The loose oil rings are marked by small grooves on the outer diameter, to prevent confusion in the selection of the correct loose oil ring for a specific diameter.

A loose oil ring marked LR-1 has one groove, LR-2 has two grooves and LR-3 has three grooves.

The loose oil rings 14-2* and 18-2* have no grooves. Their production will be stopped in the near future.

Dimensions in mm

Size	Associated shaft diameter [mm]	D ₁ [mm]	D ₂ [mm]	b
7-1 ¹⁾	55...60	124	138	12
7-2 ¹⁾	65...70...75	132	146	12
9-1	80...90	160	180	16
9-2 ²⁾	100	165	185	16
11-1	100...125	190	210	18
14-1	125...140	230	250	21
14-2*	160	240	260	21
14-2	180	245	265	21
18-1	160...180	276	300	25
18-2*	200	286	310	25
18-2	225	300	324	25
22-1	200...225	340	364	30
22-2	250...300	370	394	30
28-1	250...280	424	450	35
28-2	300...335	455	481	35
28-3	355	474	500	35
35-1	300...355	530	554	30
35-2	375...450	580	604	30
45-1	375...450	650	680	32
45-2	475...530	700	730	32
56-1	475...530	770	800	35
56-2	560...710	840	870	35
71-1	600...710	950	980	35

1) Valid only for type ZM7.

2) Valid for all diameters for type EM 9S.

* These loose oil rings have no grooves.

Sales Organisation



Headquarters and Manufacturing Plant



RENK AKTIENGESELLSCHAFT
Werk Hannover
Weltausstellungsallee 21
D-30539 Hannover
Phone: +49 (5 11) 86 01-0
Fax: +49 (5 11) 86 01-288
Email: info.hannover@renk.biz
Internet: www.renk.biz

Manufacturing Plant and Distribution Center

OMEGA RENK BEARINGS PVT. LTD.
Anand Nagar, Raisen Road
Bhopal - 462 021
India
Phone: (91 -7 55) 5 28 45 61
Fax: (91 -7 55) 2 75 16 26
Email: omtec@sancharnet.in
Internet: www.omegarenk.com

Sales Agencies

Australia
Austria
Belgium
Brazil
Canada
Czech Republic
Croatia
Finland
France
G.B. and Ireland
Hungary
India
Italy
Japan

Liechtenstein
Luxembourg
Mexico
Netherlands
Norway
PR China
Slovak Republic
Slovenia Republic
South Africa
South Korea
Spain
Switzerland
USA

Assembly and Distribution Centers



RENK Corporation
304, Tucapau Road
29334 Duncan S.C.
USA
Phone: (1-8 64) 4 33 00 69
Fax: (1-8 64) 4 33 06 36



COFICAL RENK MANCAIS DO BRASIL LTDA.
Rodovia BR-280,
km 54 - Em frente ao Parque Municipal de
Exposições
CEP 89270-000 - Guaramirim - SC - Brasil
Phone: (55-47) 337 36 400
Fax: (55-47) 337 36 499



MAN Diesel Japan Ltd.
MAN Diesel Japan Ltd.
RH Division;
Fuji Building (Room 121)
3-2-3 Marunouchi
Chiyoda-ku, Tokyo 100-0005
Japan
Phone: (81-3) 3215 1310
Fax: (81-3) 3284 0867